



CALLS FOR COACHES

Coaching Social and Emotional
Skills in Youth Sports

THE ASPEN INSTITUTE
PROJECT PLAY

THE ASPEN INSTITUTE
NATIONAL COMMISSION
ON SOCIAL, EMOTIONAL, &
ACADEMIC DEVELOPMENT



This brief was commissioned by the **Susan Crown Exchange** (SCE) to explore the role sports can play in developing young people's social and emotional skills.

FOREWORD

As a child stepping onto the tennis court, I felt like I grew three feet taller. My first coaches helped build my self-esteem and self-worth. They made the tennis court a safe place where I was challenged and encouraged to dream my dreams. And they kept me in the game, when I wanted to quit.

I was 17, facing setbacks, ready to leave the professional tennis world behind. I threw my tennis rackets into the forest, certain I was done playing. My coach, Tarik Benhabiles, asked me to give him four more months before I gave up. He challenged me to focus on learning and getting better each day. With Tarik developing my skills and confidence, I became the number one junior in the world and the world number 14 player the next year — all because my coach believed in me.

When I started my own programs, I built on what I learned from Tarik. At the Andy Roddick Foundation, we emphasize the development of social and emotional skills by setting clear goals on what we want children to achieve. We develop intentional learning opportunities with a focus on the process of learning not just the specific sports skills, but also on skills like persistence, regulation and communication.

The most important thing we do is build lasting relationships between children and adults. We provide a safe space, which means creating clear expectations and limits along with room to learn and play. We take the time to get to know each child personally and appreciate their strengths and areas for growth. We understand their frustration triggers and how to help them regulate their emotions. We celebrate often and encourage the children to celebrate each other. Finally, we partner with families, letting them know the great things their child has done each week — like learning to hit a ball or being a good friend. We tell the families why we are grateful for them, for simple things like attending the program each day.

We do all of this to help children be confident, resilient and persistent so they are ready to explore their world and own their future. We understand the profound impact that a coach can have on a kid — something I've experienced firsthand — and this report demonstrates just that. Coaches create safe spaces to learn and know when to give encouragement, even when we've already thrown in the towel. It's the high-quality relationships I've built with my childhood coaches, including Tarik, that helped me grow into the person I've become.

Thank you for everything, Tarik.

Andy S. Roddick
Founder and Chair
Andy Roddick Foundation

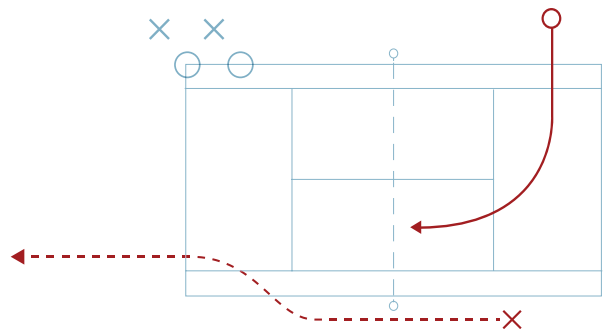

WARMUP

Beyond simply winning games, the purpose of coaches is to develop their athletes. When coaches focus on the social, emotional, cognitive and physical needs of the whole child, they help youth athletes feel safe and supported, they foster important traits such as responsibility and perseverance, they guide them in building an emotional foundation for success, and they teach teammates to respect and listen to one another.

Many children play sports, in both structured and unstructured settings. The Aspen Institute Sports & Society Program's *State of Play: 2018* report, drawing on the most recent Sports and Fitness Industry Association data, shows that 69 percent of youth ages 6 to 12 participated in a sport at least one day during 2017. The percentage of kids who participated on a regular basis in a team sport is lower, 37 percent and down from 41 percent in 2013, which has become a focus of Project Play, a Sports & Society Program initiative that helps stakeholders build healthy children and communities through sports. The hallmark of a high-quality sports experience is often a young person's relationship with a coach, yet only 36 percent of youth coaches surveyed say they have received training in effective motivational techniques.¹

It's a missed opportunity. Sports, which combine physical activity and play, represent an important environment to intentionally build important skills such as teamwork and cooperation, empathy, and planning and problem solving — just to name a few. However, it is important to remember that the development of these skills requires intentional effort and a structured approach. This brief offers a plan of action for coaches.

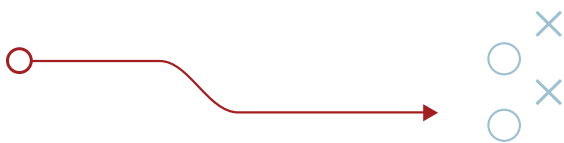

The Aspen Institute Sports & Society Program and National Commission on Social, Emotional, and Academic Development have forged a partnership with the goal of exploring the role youth sports can play in developing young people's social and emotional skills. With funding from the Susan Crown Exchange (SCE) and guidance from a strategic advisory group of researchers, program providers, coaches, and athletes including young people, we commissioned the EASEL Lab at the Harvard Graduate School of Education to produce a white paper, *Coaching Social and Emotional Skills in Youth Sports*, which synthesizes and explains the evidence behind effective strategies youth coaches can use to build these skills in their young athletes.

This brief translates the white paper into actionable calls for coaches to implement in after-school and community-based sports leagues. The brief's goals are to:

- Help coaches understand why youth sports is a great venue for developing social, emotional and cognitive skills.
- Provide strategies and best practices for coaches to name, model and create environments for youth athletes to develop and practice these skills.

¹ The Aspen Institute Project Play, "State of Play: 2018 Trends and Developments," (Washington: The Aspen Institute Sports & Society Program, 2018).

THE FOUNDATION

Coaching Social and Emotional Skills in Youth Sports explains how a positive youth development approach is critical for physical and emotional well-being. Sports and other physical activities provide ample opportunities to create an environment built on the foundational characteristics of positive youth development. Characteristics of positive youth development include:

- Youth-adult relationships — **positive and sustained relationships** with adults;
- Skill development — the practice of social, emotional and cognitive skills in a **supportive culture and climate**; and
- Opportunities for leadership — the use of these skills to enhance **youth voice and choice**.

Social and emotional skills can be grouped into three interrelated categories: cognitive regulation; emotional competencies; and social and interpersonal skills.²

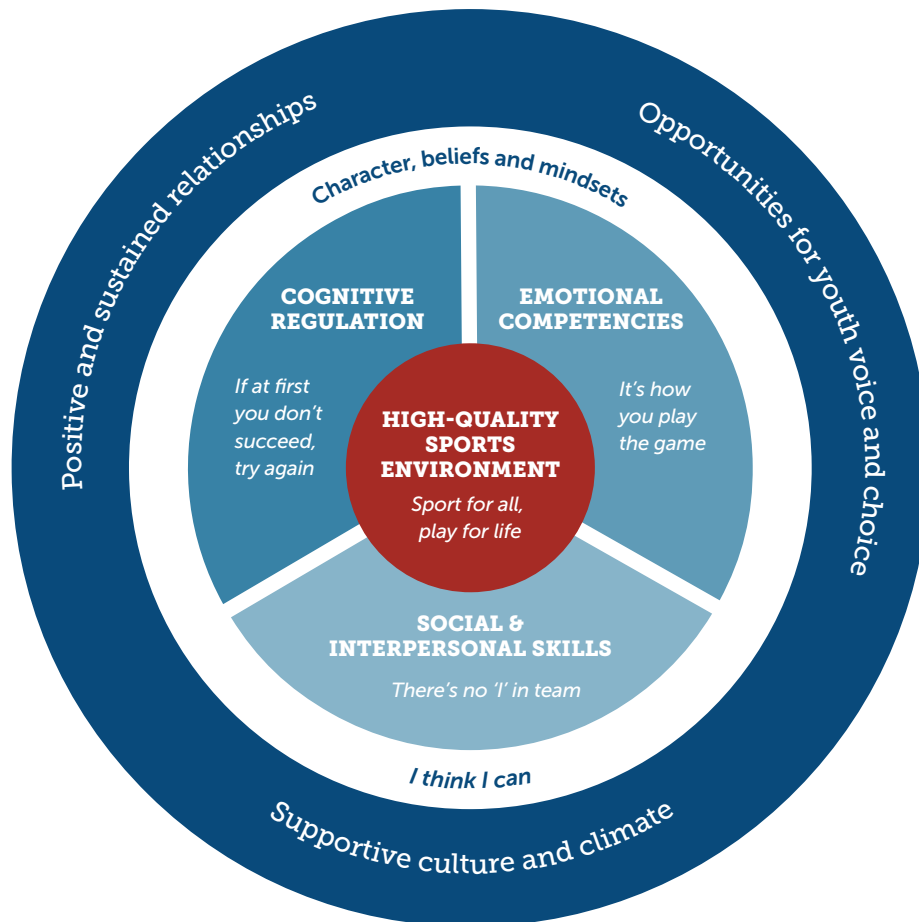

² J. Kahn, R. Bailey, and S. Jones, "Coaching Social and Emotional Skills in Youth Sports," (Washington: The Aspen Institute, 2019).

Cognitive regulation can be thought of as the basic skills required to direct behavior toward setting and reaching goals. This set of skills includes working memory, attention control and flexible thinking, as well as beliefs and attitudes that guide one’s sense of self and learning style. Children use cognitive regulation skills whenever faced with tasks that require concentration, planning (including carrying out intentional physical movement), problem solving, coordination, decision-making or overriding a strong internal or external desire.

Emotional competencies are a set of skills and understandings that help children recognize, express and regulate their emotions. This set of skills includes sympathy, empathy and perspective-taking. Emotional skills allow children to manage their own emotions and cope with different situations in constructive ways. These skills are fundamental to positive social interactions and critical to building relationships with peers and adults, which exist at the core of individual and team sports.

Social and interpersonal skills help youth accurately interpret the behavior of others. This set of skills includes interacting positively with peers and adults and effectively navigating social situations. Social and interpersonal skills build on emotional competencies. Children must be able to use these skills effectively in order to contribute to a team, resolve disagreements and coexist peacefully with others.

The development of these skills interacts with **character, beliefs and mindsets**. Character represents ways of thinking and habits that support youth working together as friends, family and community. It encompasses understanding and acting upon core ethical values like integrity, honesty and compassion. Young people’s beliefs and mindsets about themselves, others, and their circumstances — such as self-knowledge, motivation and purpose — influence how they interpret and respond to events and interactions throughout their day. Together, these skills, habits and beliefs lead to success in schooling and other community-based activities, the workplace, relationships and citizenship.³ Sports and physical activities provide a promising context for developing these skills.⁴

It is important to note that there is a developmental progression in which certain skills and competencies emerge (see next page). As the environment where children learn, grow, and play changes, so do the demands placed on them. In order to be successful, some social, emotional and cognitive skills are more or less important at different phases of development. For example, youth must learn to recognize, express and regulate their emotions before they can be expected to interact with others who are engaged in the same set of processes.⁵

3 The Aspen Institute National Commission on Social, Emotional, and Academic Development, “From a Nation at Risk to a Nation at Hope: Recommendations from the National Commission on Social, Emotional, and Academic Development,” (Washington: The Aspen Institute National Commission on Social, Emotional, and Academic Development, 2019).

4 J. Kahn, R. Bailey, and S. Jones, “Coaching Social and Emotional Skills in Youth Sports,” (Washington: The Aspen Institute, 2019).

5 S. Jones, C. A. Farrington, R. Jagers, and M. Brackett, with J. Kahn, “A Research Agenda for the Next Generation,” (Washington: The Aspen Institute National Commission on Social, Emotional, and Academic Development, 2019).

How Social and Emotional Skills Develop Over Time

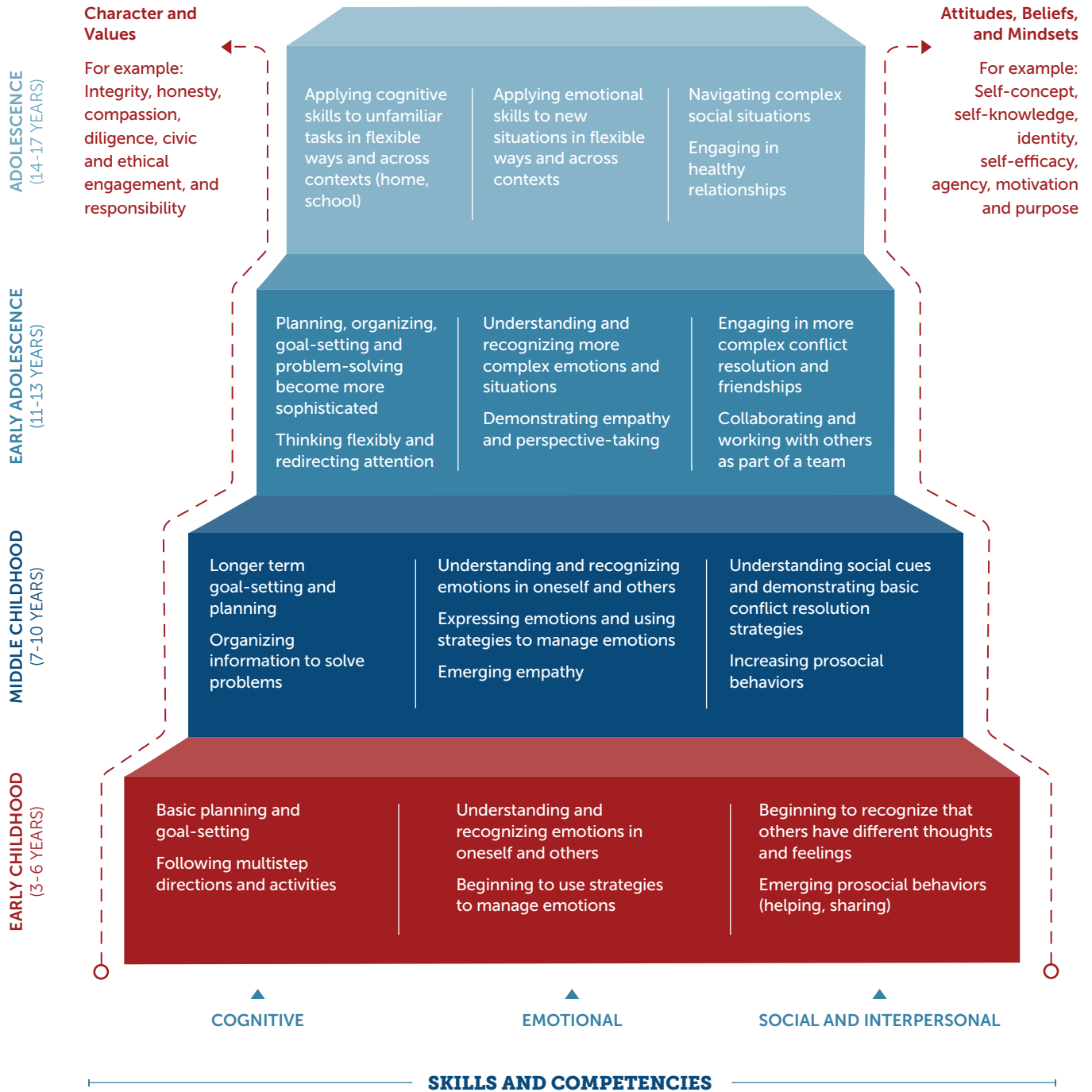

Note: This graphic originally appeared in *From a Nation at Risk to a Nation at Hope: Recommendations from the National Commission on Social, Emotional, and Academic Development*.

CALLS FOR COACHES



We call upon youth sports providers to integrate social, emotional and cognitive skill building into their programs. These Calls represent best practices that coaches can use to develop, model and foster their young athletes' holistic development. They build upon practices that coaches often already do. The Calls highlight strategies that coaches can use to create safe and supportive environments as well as forge high-quality relationships with and among their athletes. In addition, each Call provides coaches with resources to learn more.

PRACTICE SPOTLIGHT

The Practice Spotlights are simple techniques to promote the development of these skills. These best practices have been compiled in partnership with our Strategic Advisory Group of researchers, coaches, educators and providers.

RESOURCE SPOTLIGHT

Want to learn more about one of the Calls? The free, online resources featured in the Resource Spotlights have been developed by leading organizations in social and emotional learning, mentorship, sports-based youth development and coaching. Links to all the resources are available in the online version at as.pn/callsforcoaches.



01

KNOW EVERY ATHLETE'S STORY

Build positive adult-youth relationships

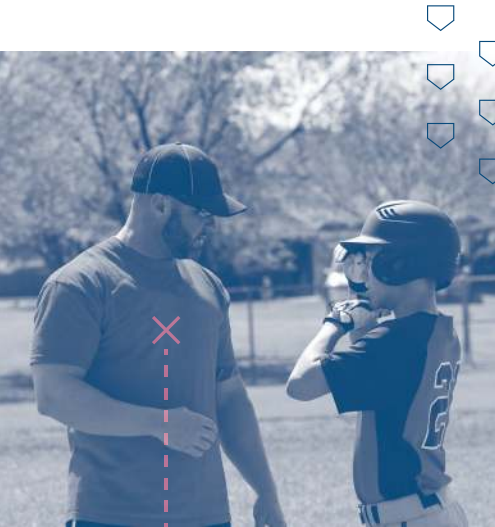

Building a trusting relationship is foundational for helping each and every youth athlete develop skills like the ability to persist in the face of challenges and work on a team. Take the time to understand why each youth athlete has made the decision to play sports. This reason reflects a young athlete's personality and goals. Furthermore, coaches should learn and appreciate individual youth experiences, interests, talents and backgrounds. In particular, coaches should understand the impacts that trauma can have on young people, on and off the field. Knowing every athlete's story provides insight about how best to create opportunities for young athletes to feel like they belong, express their opinions and assume leadership.

PRACTICE SPOTLIGHT:

- Ask every player which name they prefer and call them by that name
- Ask questions to get to know every youth, their families and their motivations
- Talk to every youth at every practice and during every game
- Talk with youth athletes about how to seek out and connect with other adults they trust
- Organize formal meetings with your players throughout the season in order to help them express their feelings, wants and needs

RESOURCE SPOTLIGHT:

- **Search Institute:** Ideas for Building Developmental Relationships
- **MENTOR:** Success Mentors Trauma-Informed Mentoring Training Curriculum

Take the time to understand why each youth athlete has made the decision to play sports

02

ESTABLISH A SUPPORTIVE TEAM CULTURE

Create a safe space that supports social and emotional skill development



Coaches are responsible for establishing a positive team culture characterized by support, safety, belonging and respect where young people are valued as decisionmakers. Supportive team culture in youth sport is built by displaying and encouraging positive attitudes and language, caring behaviors and effective emotion management. To ensure that team activities are inclusive of youth athletes with different learning styles, abilities and backgrounds, develop the unique strengths of each youth. Then, coaches should provide opportunities for each young person to shine and show leadership, including teaching and mentoring one another.

PRACTICE SPOTLIGHT:

Safety, Security & Support

- Set high expectations and clear limits on behavior
- Ensure the physical environment is free of safety concerns
- Get trained in the basics of coaching techniques, including the prevention of physical, emotional and sexual abuse
- Start and end practices on time
- Adjust the structure of practice, e.g. individual versus team activities, to accommodate players' emotions
- Establish a code of conduct that prohibits bullying and creates meaningful consequences
- Encourage high-fives or handshakes for greetings
- Incorporate team-building activities throughout the season to create dedicated opportunities for building relationships among coaches and teammates

Display and encourage positive attitude and language

DC GIRLS BASEBALL

DC Girls Baseball (DCGB) coaches give a team values sheet to their parents, players and fans at the start of the tournament season. The team values sheet outlines team philosophy and goals, specific expectations of coaches, parents, players and fans, and team needs. By sharing with everyone connected to the team, the team values sheet ensures the whole group is on the same page, making clear that DCGB focuses on effort, encouragement, sportsmanship and positivity, rather than scoreboards or statistics. Once the tournament season ends, DCGB coaches send each player an individualized feedback sheet. These sheets focus on praise on specific areas within the athlete's control, such as effort, reaction to adversity, leadership, teamwork and specific physical skills the player has been working on. They also identify areas for improvement, growth and development that consider the player's emotional, social and physical skill needs.



Youth Voice & Choice

- Create specific responsibilities to provide leadership opportunities for players, e.g. Stretch Captain, Equipment Captain or Cheer Captain, and rotate these youth leadership opportunities
 - Allow youth athletes to make and correct missteps as leaders
 - Create community by adopting practices such as composing a team cheer, selecting a team name, logo or slogan, or incorporating team-building activities into games and practices
 - Give youth athletes the opportunity to clearly define their goals and objectives
- Engage all youth athletes in co-creating and setting positive norms, rules and routines for practices and games and work with them to consistently reinforce the structure
 - Ensure all youth are included, with equitable access to activities in practices and playing time in games, being sensitive to different learning styles
 - Recognize not only extroverted leadership, but also those who lead by example

RESOURCE SPOTLIGHT:

- **Futures Without Violence:** Coaching with Courage Training Module (available Spring 2019)
- **Alliance for a Healthier Generation:** Training Center
- **National Center on Safe Supportive Learning Environments:** Creating a Safe and Respectful Environment in Our Nation's Classrooms
- **StopBullying.Gov:** Bullying Prevention Training Course
- **GLSEN:** The Safe Space Kit: Guide to Being an Ally to LGBT Students
- **U.S. Center for SafeSport:** Online Training
- **Coaching Corps:** Coaching for Youth Development Playbook
- **Up2Us Sports:** Training Resources

03

CELEBRATE EFFORT

Embody effective leadership strategies that emphasize effort, autonomy and learning

Coaches should not limit celebration to only wins, but also celebrate effort and acknowledge that mistakes are a part of learning. Youth sport teams should value and reward individual growth as well as the overall improvement of the team. Although coaches should challenge each player to do their personal best, they should also set up their athletes to experience success. Give sincere, earned praise, and use words that refer to specific actions. Conversely, avoid using criticism or rewards to shape youth athlete behavior.



PRACTICE SPOTLIGHT:

- Give shoutouts for achievement, effort and improvement at the end of the practice: players to players, coach to players and players to coach
- Encourage players to cheer for each other
- Establish a ritual for letting go of mistakes, e.g. a brushing motion across a shoulder
- Create a season-ending event to celebrate skill attainment, achievement and growth

RESOURCE SPOTLIGHT:

- **Playworks:** RecessLab Lightning Lingo
- **Positive Coaching Alliance:** Positive Charting
- **Mindset Kit:** Growth Mindset Toolkit
- **InSideOut Initiative:** Overview

GIRLS ON THE RUN

Girls on the Run (GOTR) is a nonprofit organization dedicated to empowering young women through creatively integrating running into dynamic, interactive lessons. In the GOTR 3rd-5th Grade Program, girls and their running buddies celebrate the end of each season with a non-competitive 5k event to culminate their 10-week curriculum focused on building social and emotional skills.

04

FOCUS ON THE SKILLS THAT MATTER

Prioritize and provide opportunities for direct skill building and practice

Coaches should identify and communicate the comprehensive set of skills (physical, social, emotional and cognitive) they hope to develop in their youth athletes. Reinforcing all types of skills in team rituals and routines benefits everyone and builds sports environments that are higher in quality and, ultimately, more satisfying and valuable for coaches and athletes. Reflection with athletes on experiences and skills developed in games or practices creates an opportunity to discuss how to apply that learning at home, in school and in the community.

PRACTICE SPOTLIGHT:

- Identify and share the particular skills you are aiming to build in your athletes — whether that's working as a team, staying motivated, empathizing with teammates or other key skills
- Encourage parents and caregivers to reinforce these skills by talking about what they are, what they mean and what these behaviors can look like at home
- Have players set goals and intentions regarding their physical, social, emotional and cognitive skill development
- Establish a circle-up ritual at the start of every practice and game and a reflection ritual at the end of every practice and game that includes discussion of the skills being prioritized
- Have conversations about how to use experiences and skills from games or practices in other settings, e.g. discuss how mistakes are a part of learning and improving



Have players set goals and intentions regarding their physical, social, emotional and cognitive skill development

RESOURCE SPOTLIGHT:

- **Playworks:** SEL Game Guide
- **Playworks:** Game Library
- **Coaching Corps:** Character Building Attributes
- **The First Tee:** 9 Core Values
- **Character.org:** 11 Principles Sourcebook
- **Preparing Youth to Thrive:** SEL Resources

AMERICA SCORES

America SCORES combines team-based soccer leagues, poetry and writing, and youth-led service projects. America SCORES' holistic program has two central tenets. First, it utilizes the sport of soccer to teach sportsmanship, discipline, problem-solving and teamwork as well as to encourage physical activity. Second, the program incorporates studying, writing and performing poetry for the development of creative thinking, literacy and speaking skills. The bonds of trust that youth build by sharing their vulnerabilities with each other through poetry makes them better soccer teammates. The confidence they build by positively affecting their communities through service projects makes them better leaders on and off the field. These shared experiences deepen their commitment not just to their beloved sport, but to each other and to their team — resulting in kids who are both physically and emotionally healthier.



05

BE A ROLE MODEL

Model good character and decision-making

As leaders in youth sport, coaches should model positive behavior in their interactions with other adults and youth athletes, with opponents and referees, and particularly when mediating conflicts. Coaches should demonstrate and discuss the difference between constructive and destructive conduct. During frustrating situations, coaches should remain calm and display appropriate behavior. If you make a mistake, model accountability by taking responsibility for your actions and owning up. It is important that youth athletes see that coaches are learning alongside them while remaining exemplars.

PRACTICE SPOTLIGHT:

- Participate in drills with players
- Practice the positive interactions that are encouraged of players
- Practice self-care and engage in reflection around your own social and emotional well-being
- Be cognizant of your own and others' perspectives
- Manage conflicts with calmness and clarity, acknowledging player feelings and emotions

RESOURCE SPOTLIGHT:

- **MENTOR:** Mentoring resources and webinars
- **National Mentoring Resource Center:** Resources, guides and handouts
- **Preparing Youth to Thrive:** Self-Assessment
- **The Rhodes Lab:** Natural Mentoring
- **Futures Without Violence:** Coaching Boys Into Men

During frustrating situations, coaches should remain calm and display appropriate behavior

06

BE COACHABLE

Seek opportunities for support, training and professional development

A key component of teaching social and emotional skills is the ability to assess and manage one's own social and emotional state. Coaches should have the mindset that there is always more to learn, and that there is always room for improvement. To commit to their own continued improvement, coaches should understand the foundational skills for how we learn and be open to adapting coaching strategies and style. Free, online resources, included throughout this brief, are great options for continued learning that can be accessed anywhere. Additionally, coaches should seek to learn from their own athletes. By collecting feedback from athletes and incorporating it into practices, coaches are empowering children to use their voices while improving their coaching competencies.

PRACTICE SPOTLIGHT:

- Participate in learning opportunities with other coaches in the league or in the community such as observing other coaches' practices or practicing in league-wide professional development
- Actively seek out and participate in professional development to grow your coaching skills
- Get knowledgeable about coaching techniques that identify and prevent physical, emotional and sexual abuse
- Collect athlete feedback and incorporate into practices

RESOURCE SPOTLIGHT:

- **Team USA:** USOC Quality Coaching Framework
- **Positive Coaching Alliance:** Development Zone Resource Center
- **SHAPE America:** National Standards for Sport Coaches



HOW TO COACH KIDS.ORG

The How to Coach Kids website aggregates resources to train coaches by sport and topic in a new, free 30-minute course on the general principles of coaching children through age 12. Co-developed by Nike and the U.S. Olympic Committee with the help of the Aspen Institute, this course helps new and novice coaches plan a great practice, keep kids safe, use teaching strategies to help kids learn and work with families.

07

JOIN FORCES

Engage with families, schools and other community organizations

Coaches should think about their role in a child's web of support and join forces with other adults in their lives, especially for reflection and debrief. As part of knowing every athlete's story, seek to partner with the other important adults in your athletes' lives to better provide the support they need. Coaches should regularly communicate with families — including sharing team expectations and values — and remain open to conversations with parents and guardians. As an active member of the community, coaches should strive to increase opportunities and access for high-quality sports experiences for all young people.

PRACTICE SPOTLIGHT:

- Host a preseason meeting with families to discuss your program philosophy, goals and intentions
- Design a practice or family hour for parents/caregivers and siblings
- Learn about the language and strategies used in schools or at home and, when possible, reinforce these lessons in practices and games
- Collaborate with other coaches to design effective practices
- Talk with parents/caregivers about issues arising with their children
- Find regular opportunities to assess and share progress with families
- Start a conversation around what quality coaching looks like to provide a healthy and positive sports experience for youth across your community

RESOURCE SPOTLIGHT:

- **National Commission on Social, Emotional, and Academic Development:** Building Partnerships
- **Project Play:** Teamwork Toolkit (available Fall 2019)
- **Project Play:** Healthy Sport Index
- **Up2Us Sports:** Case Studies
- **Center for Promise:** Defining Webs of Support: A New Framework to Advance Understanding of Relationships and Youth Development



FLAG STAR FOOTBALL

Flag Star Football, a youth flag football league, provides four guiding principles for the parents of participating youth athletes. The four principles include the following: Arrive With a Purpose, Set the Tone; Don't Be a Jerk; Make (and Encourage) Mistakes; and Do Better. The guidelines emphasize the parent as the ultimate role model for youth athletes by stating that "YOU [the parent] are in charge of the environment." The guidelines further detail expectations for parents and provide the rationale for each.



COOLDOWN AND REFLECTION

As this brief demonstrates, sports presents an incredible and unique opportunity to help all youth athletes build and practice social, emotional and cognitive skills. Although difficult, measuring the progression of social, emotional and cognitive skills would be valuable to coaches and youth athletes. There are not yet research-supported measurement tools that have been utilized in the context of youth sports; this represents an area for exploration. As these tools are created, the focus should be on helping coaches and athletes identify strengths and room for growth, recognizing that everyone develops at their own pace.

This opportunity cannot be realized without the backing and understanding of coaches. Coaches lead the way in building these competencies in their athletes. You, as coaches and important role models in young people's lives, have the critical role to elevate the importance of these skills and begin implementing these calls to strengthen your teams and programs. By intentionally developing social, emotional and cognitive skills in your players, you are creating a higher-quality sports environment, cultivating a love of sports and preparing your young athletes to excel in the world of sports and beyond.

TEAM ROSTER

The Aspen Institute

The Aspen Institute is a nonpartisan forum for values-based leadership and the exchange of ideas.

[AspenInstitute.org](https://www.aspeninstitute.org)

Aspen Institute Sports & Society Program

The mission of the Sports & Society Program is to convene leaders, facilitate dialogue and inspire solutions that help sports serve the public interest. An initiative of the program, Project Play develops, applies and shares knowledge that helps stakeholders build healthy communities through sports.

[ProjectPlay.us](https://www.projectplay.us) | [SportsAndSociety.org](https://www.sportsandsociety.org)

Aspen Institute National Commission on Social, Emotional, and Academic Development

The Aspen Institute National Commission on Social, Emotional, and Academic Development was created to engage and energize communities in re-envisioning learning to support the whole child. The Commission's culminating report, *From a Nation at Risk to a Nation at Hope*, was released in January 2019.

[NationAtHope.org](https://www.nationathope.org)

Susan Crown Exchange

Susan Crown Exchange (SCE) is a Chicago-based foundation invested in shaping an ecosystem of anytime, anywhere learning to prepare youth to adapt and thrive in a rapidly changing and highly connected world. Through grantmaking programs in digital learning and social and emotional learning, SCE helps identify, codify and promote high-quality opportunities for young people to learn and grow in out-of-school time.

[SCEfdn.org](https://www.scefdn.org)

Strategic Advisory Group

Our deepest thanks to the members of our Strategic Advisory Group of researchers, coaches, practitioners, educators and providers. The Strategic Advisory Group convened in September 2018 in Washington D.C., and provided regular support and feedback during the development of this brief. Members include:

Dr. Jennifer Agans, Assistant Professor, Pennsylvania State University, College of Health and Human Development; **Paul Caccamo**, Founder & CEO, Up2Us Sports; **Dr. James P. Comer**, Maurice Falk Professor of Child Psychiatry, Yale Child Study Center; **Elizabeth Cushing**, President, Playworks; **Carl Ehrlich**, Founder & CEO, Flag Star Football; **Joe Ehrmann**, Co-Founder, InSideOut Initiative; **Dr. Wade Gilbert**, Professor, Fresno State University, College of Health and Human Services; **Yesenia Gorbea**, Senior Program Specialist, Futures Without Violence; **Dr. Dan Gould**, Director, Institute for the Study of Youth Sports, Michigan State University, College of Education; **Bethany Rubin Henderson**, Network President, America SCORES; **Bonnie Hoffman**, Coach, DC Girls Baseball; **Dr. Noelle Hurd**, Scully Family Discovery Associate Professor, University of Virginia, Department of Psychology; **Dr. Stephanie Jones**, Director, EASEL Lab, Harvard Graduate School of Education; **Jennifer Kahn**, Research Manager, EASEL Lab, Harvard Graduate School of Education; **Doug Karr**, President & CEO, Character.org; **Dr. John McCarthy**, Director, Institute for Athletic Coach Education, Boston University, Wheelock College of Education; **Michael McFarlane**, Coach, Flag Star Football; **Wayne Moss**, Executive Director, National Council of Youth Sports; **Lauren Puzen**, Senior Partnership Manager, Alliance for a Healthier Generation; **Jody Redman**, Co-Founder, InSideOut Initiative; **Dr. Allison Riley**, Senior Vice President, Programming and Evaluation, Girls on the Run; **Suzanne Sillett**, Director of Education and Quality, Coaching Corps; **Dr. Ashlyn Smith**, Senior Manager, Research and Evaluation, Special Olympics; **Richard Tagle**, Executive Director, Andy Roddick Foundation; **Jim Thompson**, Founder & CEO, Positive Coaching Alliance; and **Jeff York**, Vice President, Consumer Research, The First Tee.

And thanks to the additional advisors who consulted on previous drafts of this report:

Chris Borland, former NFL player; **Kate Carpenter**, America SCORES Milwaukee; **Janet Carter**, Coaching Corps; **Diana Cutaia**, Coaching Peace; **Delia Hagan**, MENTOR; **Alex Hooker**, Bechtel Foundation; **Dr. Richard Lerner**, Tufts University; **Lynne Lee**, Coaching Corps; **Dr. Will Mayer**, Sacred Heart University; **Jamison Merrill**, Up2Us Sports; **Lisa Perry**, Alliance for a Healthier Generation; **Dudney Sylla**, MENTOR; **Dr. Maureen Weiss**, University of Minnesota; and **Luella Williams**, Up2Us Sports.

CALLS FOR COACHES

01

KNOW EVERY ATHLETE'S STORY

Build positive adult-youth relationships

02

ESTABLISH A SUPPORTIVE TEAM CULTURE

Create a safe space that supports social and emotional skill development

03

CELEBRATE EFFORT

Embody effective leadership strategies that emphasize effort, autonomy and learning

04

FOCUS ON THE SKILLS THAT MATTER

Prioritize and provide opportunities for direct skill building and practice

05

BE A ROLE MODEL

Model good character and decision-making

06

BE COACHABLE

Seek opportunities for support, training and professional development

07

JOIN FORCES

Engage with families, schools and other community organizations

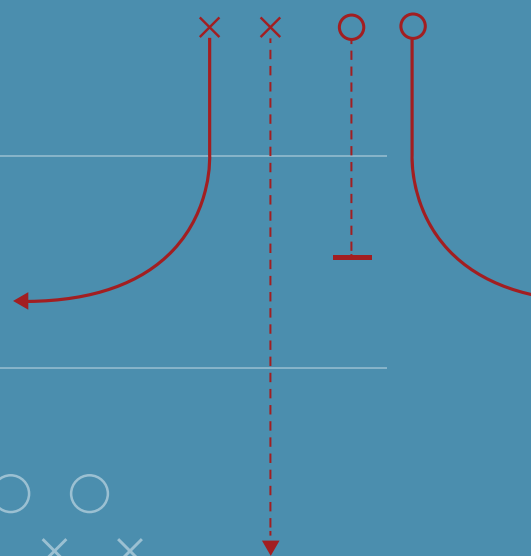
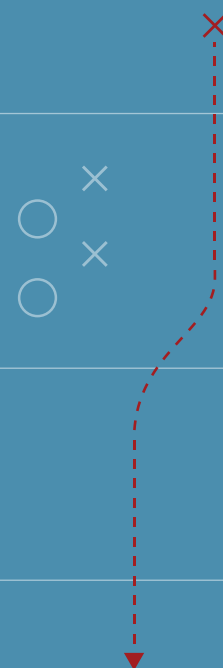

CHECKLIST

First Practice

- Host a preseason meeting with parents to discuss your program philosophy, goals and intentions
- Ask every player which name they prefer and call them by that name
- Talk with youth athletes about how to seek out and connect with other adults they trust
- Co-create and set positive norms, rules and routines for practices and games

Planning Practice / Pregame

- Collaborate with other coaches to design effective practices
- Ensure the physical environment is free of safety concerns
- Set high expectations and clear limits on behavior
- Have players set goals and intentions regarding their physical, social, emotional and cognitive skill development
- Allow athletes to serve in leadership roles and maintain a rotation schedule so all players have the opportunity to lead

During Practice / Day of Game

- Start and end practices on time
- Participate in drills with players
- Practice positive interactions that are encouraged of players
- Adjust the structure of practice and activities to accommodate players' emotions
- Create community by adopting practices such as composing a team cheer, selecting a team name, logo or slogan, or incorporating team-building activities into games and practices
- Encourage high-fives or handshakes for greetings

After Practice / Postgame

- Give shoutouts for achievement, effort and improvement at the end of the practice: players to players, coach to players and players to coach
- Collect athlete feedback and incorporate into practices
- Talk with parents/caregivers about issues arising with their children
- Encourage parents and caregivers to reinforce these skills by talking about what they are, what they mean and what these behaviors can look like at home

Ongoing: Every Practice, Every Game

- Reinforce the norms, rules and routines
- Ensure all youth are included, with equitable access to activities, being sensitive to different learning styles
- Establish a code of conduct that prohibits bullying and establishes consequences
- Ask questions to get to know every youth, their families and their motivations
- Organize formal meetings with your players throughout the season in order to help them express their feelings, wants and needs
- Be cognizant of your own and others' perspectives
- Practice self-care, engage in reflection around your own social and emotional well-being
- Talk to every youth at every practice and during every game

Learn more at aspn.org/callsforcoaches



Commissioned by the
Susan Crown Exchange